



Very High Power Disconnectors

PBD (Plain Bars Disconnectors)

2000 V DC - 20 kA to 160 kA

Single pole / Double pole / Change-over

Aluminum Terminals

- Visible break
- Absorb dimensional variations due to expansions (Flexible joints are not necessary)
- Low and constant voltage drop
- Supported by busbars (no frame required)
- Possibility of covering up totally one side of the disconnector (for protection & isolation)
- Easy connections by welding to high section aluminium busbars
- Large customization possible with:
 - Actuators (motor, pneumatic, manual)
 - Auxiliaries (limit switches, locks, control boxes)
 - Adaptation to the connecting busbars.
- According to IEC 60947-3 / IEC 60077-1

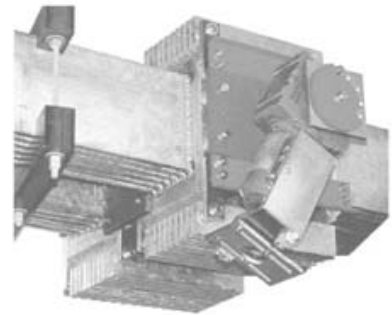

Main technical characteristics

Electrical Data

- Temperature rise at nominal current (with 40°C max. Ambient temperature) less than : 65°C
- Voltage drop at nominal current less than : 60 mV
- Peak short-circuit current withstand (upon circuit configuration) : 8 x (Nominal current)
- Dielectric withstand strength
 - Between live parts in open position : 10 kV - 50 Hz - 1 min
 - Between live parts and earth : 10 kV - 50 Hz - 1 min
 - Between auxiliary contacts and earth : 2.5 kV - 50 Hz - 1 min
 - Between motor (AC) and earth : 2 kV - 50 Hz - 1 min

Mechanical Data

- Built-in deformability (longitudinally (dL) / transversally (dT) / axially (dA)) : 20 / 20 / 20 mm (higher values available upon request)
- Mechanical endurance (with respect to maintenance instructions). Higher endurance upon : 1000 Cycles
- Typical duration of opening or dosing operation
 - With motor operation : Less than 20 seconds
 - With pneumatic operation : Less than 1 second
- Punctual contact temperature on live parts withstand without equipment damages : 140°C

Technology

- Copper terminals or mixt optionnal
- All contacts are fitted with solid silver, high temperature brazed (special process)
- Mechanically independant mobile contact arms with high-pressure springs
- Electrical contact with solid pure silver, point to point, contact tips.
- Operation mechanism by a toggle closed system
- Upon request, two poles or change-over design by side association of two disconnectors

Main dimensions Single Assembly:

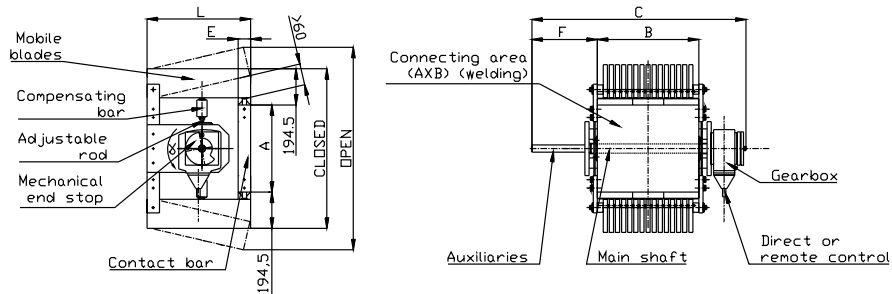

Double Assembly:

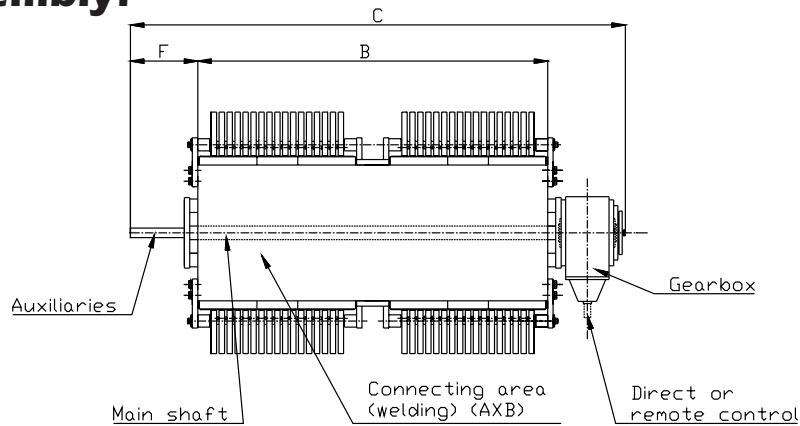

	Ir (kA)	Nb. of blades	Ø blade (A/mm ²)	B (mm)	C (mm)	E (mm)	L (mm)	Weight (kg) A=500
Simple Assembly	20	2x7	0.45	290	830	90	530	200
	25	2x9	0.43	350	890	90	530	220
	30	2x10	0.47	380	920	90	530	235
	35	2x12	0.46	440	1000	90	530	270
	40	2x14	0.45	500	1060	90	530	305
	45	2x16	0.44	560	1120	90	530	340
	50	2x18	0.43	620	1180	90	530	375
	55	2x20	0.45	680	1240	90	530	410
	60	2x22	0.47	740	1300	90	530	445
	70	2x24	0.46	800	1350	120	560	500
Double Assembly	80	4x14	0.45	1120	1660	120	560	750
	90	4x16	0.44	1240	1790	120	560	830
	100	4x17	0.46	1300	1850	120	560	880
	110	4x19	0.45	1420	1970	120	560	1080
	120	4x20	0.47	1480	2030	120	560	1120
	130	4x22	0.46	1600	2150	120	560	1200
	140	4x24	0.46	1720	2210	120	560	1290
	150	4x26	0.45	1840	2390	120	560	1370
	160	4x27	0.46	1900	2450	120	560	1500

Dimensions: A: standard = 500 mm (600 or 700 mm as option)
 F: standard = 250 mm
 Blade section = 160 x 20 mm

Ferraz Shawmut has it all for defining and offering customized solutions to meet your most specific requirements :

- . Adapted drives or control units
- . Adapted technical performances (short-circuit current capability, endurance ,small load make / break capacity).