

## High-Current Disconnectors

### NORD Range

1500 V DC - 14 kA to 140 kA

Single pole / Double pole / Change-over

Aluminum or Copper Terminals

- Accept busbar dilatations thanks to built-in deformability (Flexible joints are not necessary)
- Low and constant voltage drop
- Self-cleaning effect on contact
- High short-circuit current withstand
- Large insulation and creepage distances
- Easy connections to:
  - Aluminium busbars by welding
  - Copper busbars by bolting
- Large customization possible with:
  - Actuators (motor, pneumatic, manual)
  - Auxiliaries (limit switches, locks, control boxes)
  - Adaptation to the connecting busbars.
- According to IEC 60947-3 / IEC 60077-1 (NFF 16101 / 16102)

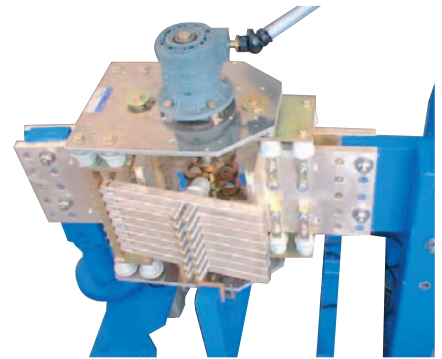

### Main technical characteristics

#### Electrical Data

- Temperature rise at nominal current (with 40°C max. Ambient temperature) less than : 65°C
- Typical temperature rise at nominal current (with 40°C max. Ambient temperature) : 15°C above busbars
- Typical voltage drop at nominal current : 40 mV
- Peak short-circuit current withstand (upon circuit configuration) : 8 x (Nominal current)
- Dielectric withstand strength
  - Between live parts in open position : 10 kV - 50 Hz - 1 min
  - Between live parts and earth : 10 kV - 50 Hz - 1 min
  - Between auxiliary contacts and earth : 2.5 kV - 50 Hz - 1 min
  - Between motor (AC) and earth : 2 kV - 50 Hz - 1 min
- SCR leakage current breaking capacity (upon request) : 1 A - 100 V DC L/R = 5 ms
- Power breaking capacity up to 100 kA - 100 V DC - L/R < 20 msec : Upon request

#### Mechanical Data

- Built-in standard deformability (longitudinally (dL) / transversally (dT) / axially (dA)) (higher values available upon request) : 25 / 80 / 10 mm
- Mechanical endurance (with respect to maintenance instructions). Higher endurance upon request : 20 000 Cycles
- Typical duration of opening or closing operation
  - With motor operation : 3 to 12 seconds
  - With pneumatic operation : Less than 1 second
- Punctual contact temperature on live parts withstand without equipment damages : 140° C

## Technology

- Visible break by direct seeing of the mobile silver-plated copper contacts
- Mechanically independant mobile contact arms with high-pressure springs
- Electrical contact with silver to silver contact
- Insulation with Fiberglass reinforced polyester insulators
- Operation mechanism of bichromate galvanized steel by a toggle closed system
- Disconnectors are self-supporting - Busbars support must be sized to withstand the disconnector additional weight
- Upon request, choice of input and output terminals in aluminium or silver-plated copper
- Upon request, two poles or change-over design by side association of two disconnectors

## Main dimensions

Nominal current(kA)	No. mobile contacts	A mm	B mm	Weight kg
14	12	200	90	130
18	16	255	90	150
22	20	310	90	175
27	24	365	90	200
32	28	420	90	225
35	32	475	90	250
39	36	530	90	280
43	40	585	90	305
47	44	640	90	330
51	48	695	97	355
55	52	750	97	380
58	56	805	97	410
62	60	860	97	435
66	64	915	97	460
70	68	970	97	485

In	C	C'	D	E	E'
>47 kA	892.5	460	842.5	820	460
≤ 47 kA	802.5	432.5	780	792.5	432.5

### Deformability

(Factory settings at : dL: ± 12.5 - dT: ±40 - dA: ±5)

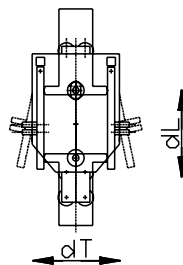
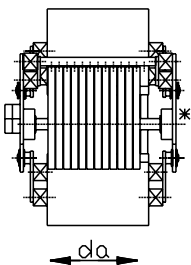

Typical bolting scheme on copper connecting plates d, chosen from 0 to 60 mm

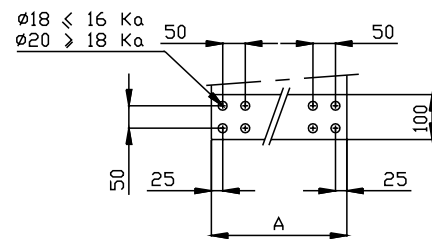



## Aluminium type

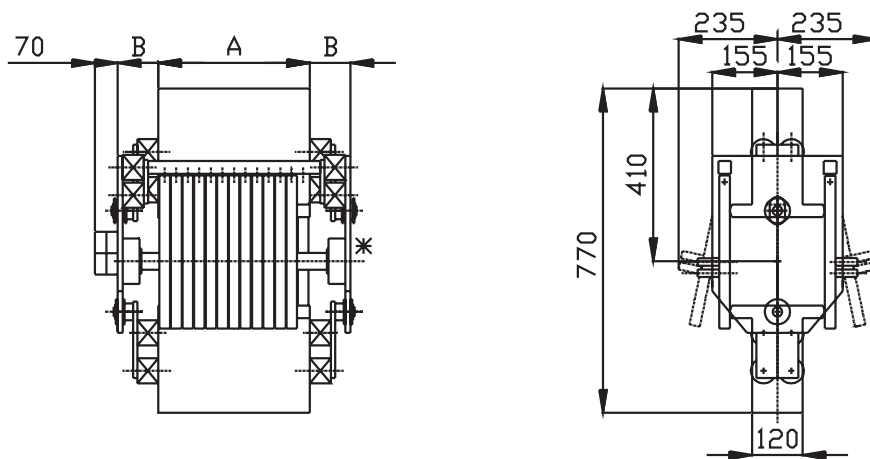

\* .Control device  .Auxiliary contact

## Copper type

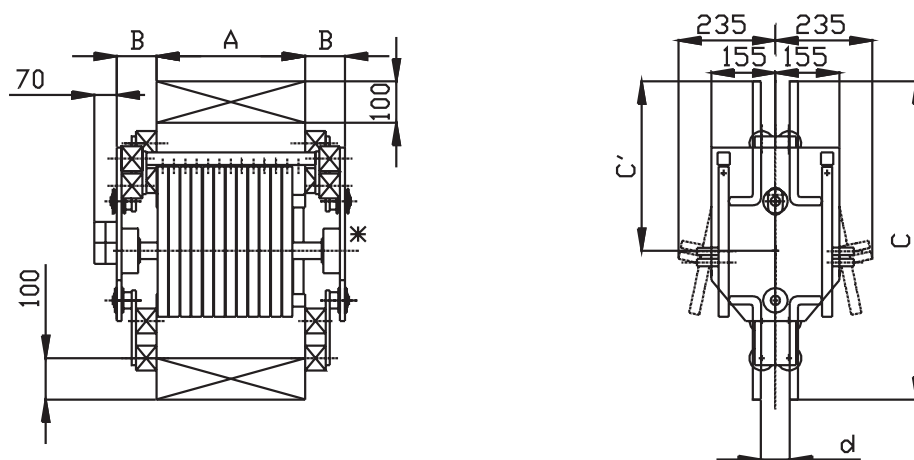

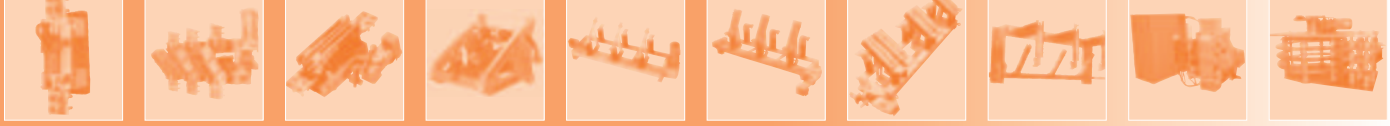

\* .Control device  .Auxiliary contact  .Bolting scheme below

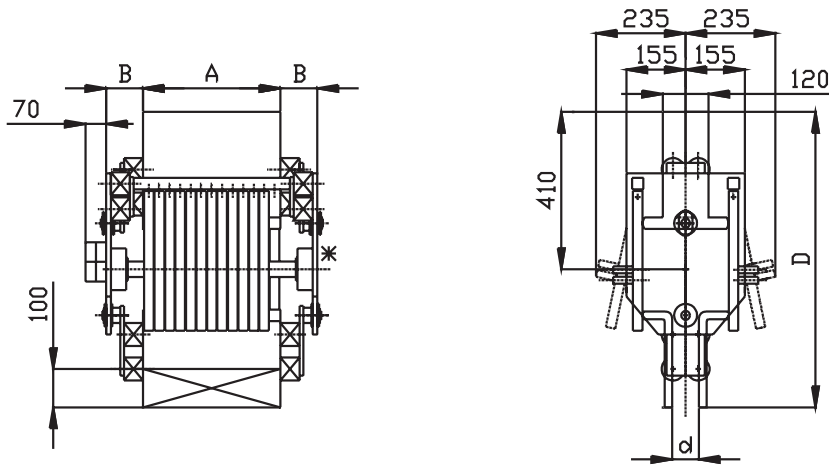

## Aluminium/Copper type



\* .Control device  .Auxiliary contact  .Bolting scheme below 

## Copper/Aluminium type

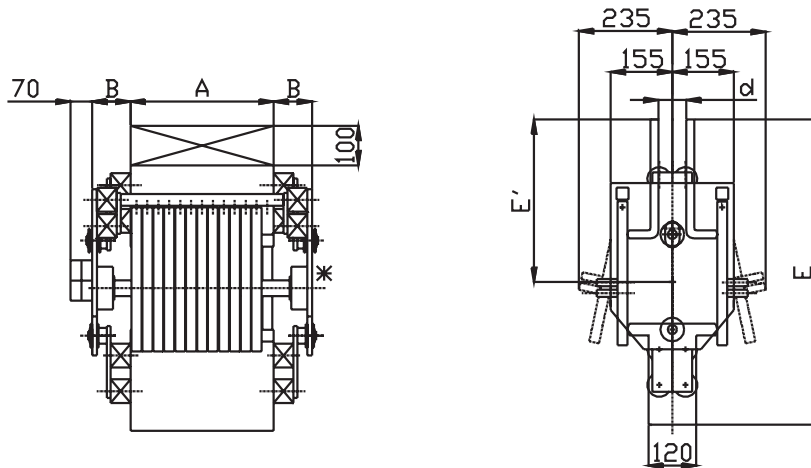

\* .Control device  .Auxiliary contact  .Bolting scheme below 

FERRAZ has it all for defining and offering customized solutions to meet your most specific requirements :

- Adapted drives or control units
- Enclosures for switch protection
- Adapted technical performances (short-circuit current capability, endurance, grounding contacts)



## High-Current Disconnectors

### NORD-R Range

1500 V DC - 50 kA to 10 kA

Single pole / Double pole / Change-over

Aluminum or Copper Terminals

- Accept busbar dilatations thanks to built-in deformability (Flexible joints are not necessary)
- Low and constant voltage drop
- Self-cleaning effect on contact
- High short-circuit current withstand
- Large insulation and creepage distances
- Easy connections to:
  - Aluminium busbars by welding
  - Copper busbars by bolting
- Large customization possible with:
  - Actuators (motor, pneumatic, manual)
  - Auxiliaries (limit switches, locks, control boxes)
  - Adaptation to the connecting busbars.
- According to IEC 60947-3 / IEC 60077-1 (NFF 16101 / 16102)

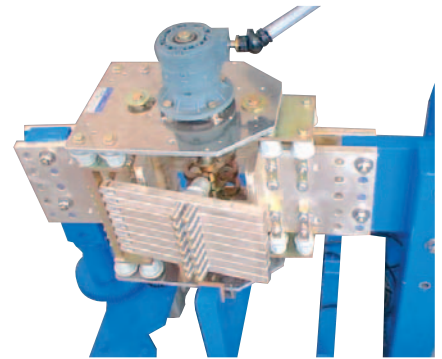

### Main technical characteristics

#### Electrical Data

- Temperature rise at nominal current (with 40°C max. Ambient temperature) less than : 65°C
- Typical temperature rise at nominal current (with 40°C max. Ambient temperature) : 15°C above busbars
- Typical voltage drop at nominal current : 40 mV
- Peak short-circuit current withstand (upon circuit configuration) : 8 x (Nominal current)
- Dielectric withstand strength
  - Between live parts in open position : 10 kV - 50 Hz - 1 min
  - Between live parts and earth : 10 kV - 50 Hz - 1 min
  - Between auxiliary contacts and earth : 2.5 kV - 50 Hz - 1 min
  - Between motor (AC) and earth : 2 kV - 50 Hz - 1 min
- SCR leakage current breaking capacity (upon request) : 1 A - 100 V DC L/R = 5 ms
- Power breaking capacity up to 100 kA - 100 V DC - L/R < 20 msec : Upon request

#### Mechanical Data

- Built-in standard deformability (longitudinally (dL) / transversally (dT) / axially (dA)) (higher values available upon request) : 25 / 50 / 10 mm
- Mechanical endurance (with respect to maintenance instructions). Higher endurance upon request : 20 000 Cycles
- Typical duration of opening or closing operation
  - With motor operation : 3 to 12 seconds
  - With pneumatic operation : Less than 1 second
- Punctual contact temperature on live parts withstand without equipment damages : 140° C

## Technology

- Visible break by direct seeing of the mobile silver-plated copper contacts
- Mechanically independant mobile contact arms with high-pressure springs
- Electrical contact with silver to silver contact
- Insulation with Fiberglass reinforced polyester insulators
- Operation mechanism of bichromate galvanized steel by a toggle closed system
- Disconnectors are self-supporting - Busbars support must be sized to withstand the disconnector additional weight
- Upon request, choice of input and output terminals in aluminium or silver-plated copper
- Upon request, two poles or change-over design by side association of two disconnectors

## Main dimensions

Nominal current(kA)	No. mobile contacts	A mm
14	12	200
18	16	255
22	20	310
27	24	365
32	28	420
35	32	475
50	36	530
55	40	585
60	44	640
66	48	695
72	52	750
78	56	805
83	60	860
88	64	915
95	68	970
102	72	1025

In	C	C'	D	E	E'
≥ 50 kA	892.5	460	842.5	820	460

### Deformability

(Factory settings at : dL: ± 12.5 - dT: ±40 - dA: ±5)

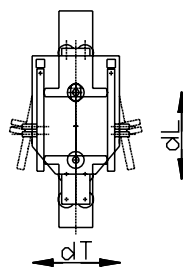
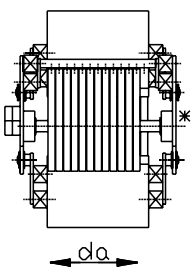

Typical bolting scheme on copper connecting plates d, chosen from 0 to 60 mm

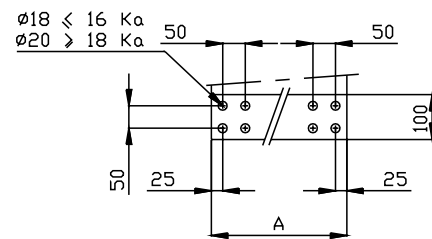



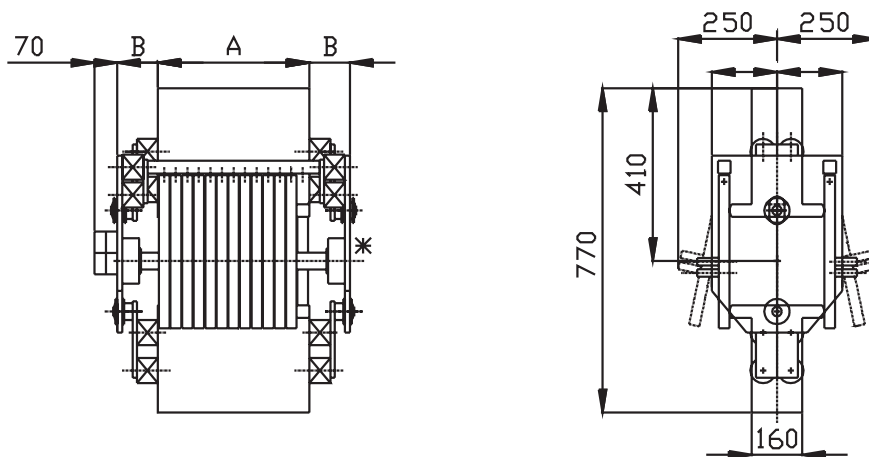

## Aluminium type

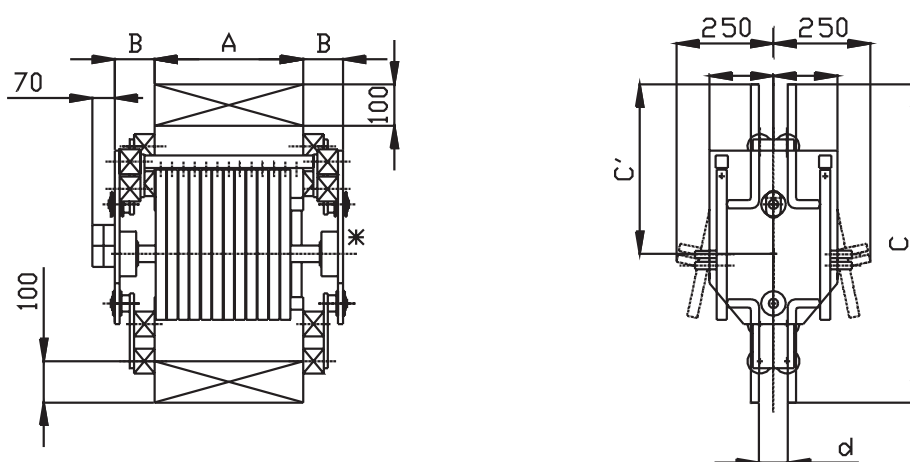

\* .Control device  .Auxiliary contact

## Copper type



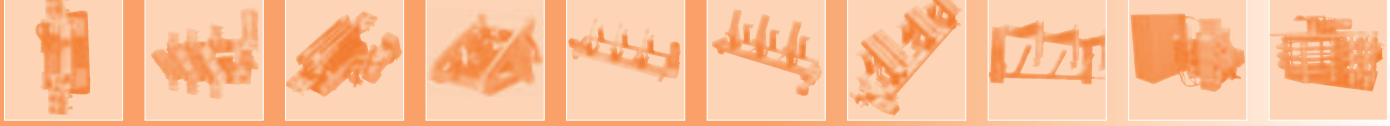

\* .Control device  .Auxiliary contact  .Bolting scheme below



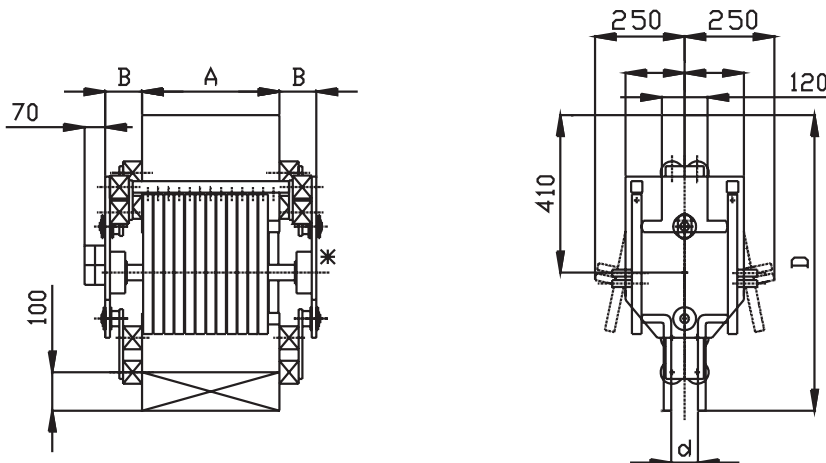

## Aluminium/Copper type

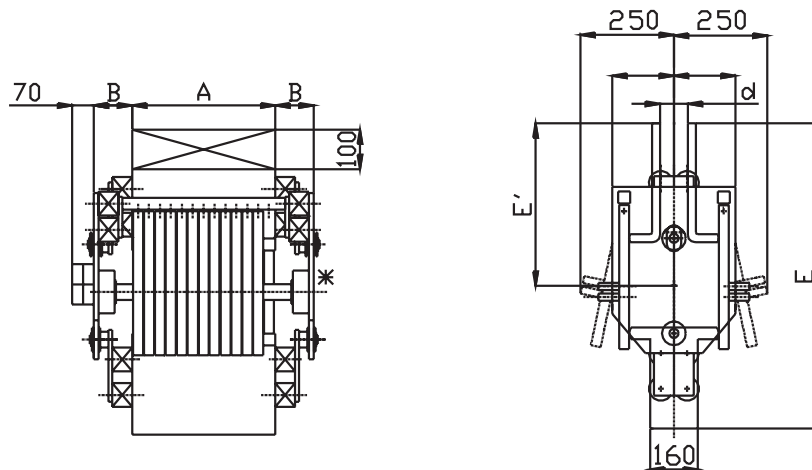

\* .Control device  .Auxiliary contact  .Bolting scheme below

## Copper/Aluminium type



\* .Control device  .Auxiliary contact  .Bolting scheme below

FERRAZ has it all for defining and offering customized solutions to meet your most specific requirements :

- Adapted drives or control units
- Enclosures for switch protection
- Adapted technical performances (short-circuit current capability, endurance, grounding contacts)