



High-Voltage Fuse-Links

according to VDE 0670 T 402



Notes

A large area of the page containing horizontal dashed lines for taking notes.

Ferraz Shawmut serves the Power Production & Distribution market with :

- Limitor®-branded high voltage fuse-links
- Nortroll®-branded fault indicators

The combination of these two latter provides the utility market with well fitted protection against disastrous effects, electrical and mechanical, of short-circuits (Limitor®) and easier maintenance via very fast location of short-circuits and earth faults (Nortroll®). Ferraz Shawmut is involved in the utility market from awhile and is able to provide any support required by this market.

Among Limitor® solutions we introduce our brand-new line of high-voltage fuse-links complying with VDE 0670 T402 and VDE 0670 T4. The latter is identical to the International Standard IEC 60282-1 (High-voltage fuses "current limiting fuse-links"). This line is designed, manufactured and tested as per our Quality Management System which is certified to the ISO 9001:2000 International standard.

Ferraz Shawmut high-voltage fuse-links have parallel connected pure silver fuse-link elements. The design and method of production of the elements ensures narrow tolerances of time-current characteristics. The fuse-link elements are wound on a ceramic support and are attached to contact carriers by means of spot-welding. The contact carriers are fitted inside the silver plated copper end caps by spot welding. The copper end caps themselves are fitted onto the porcelain tube which is glazed inside and outside. The end caps are furthermore mechanically fixed to the porcelain tube in a way that tightness against ingress of humidity is guaranteed. The tightness of each single Ferraz Shawmut high-voltage fuse-link is assured by a low-pressure test in a water bath.

This brand-new Limitor fuse-links line is intended to outdoor use. It encompasses three product ranges:

- The back-up fuse-link range with striker
- The back-up fuse-link range with striker and internal thermal protection
- The general purpose fuse-link range with striker

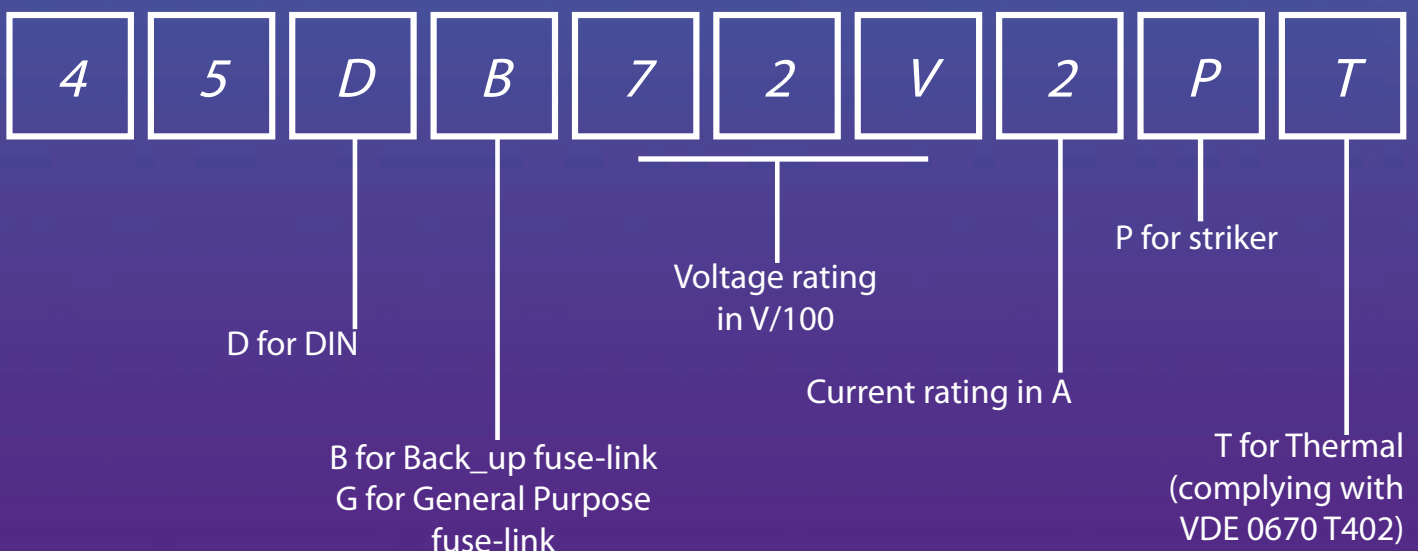

Technical Overview

Back-up fuses range

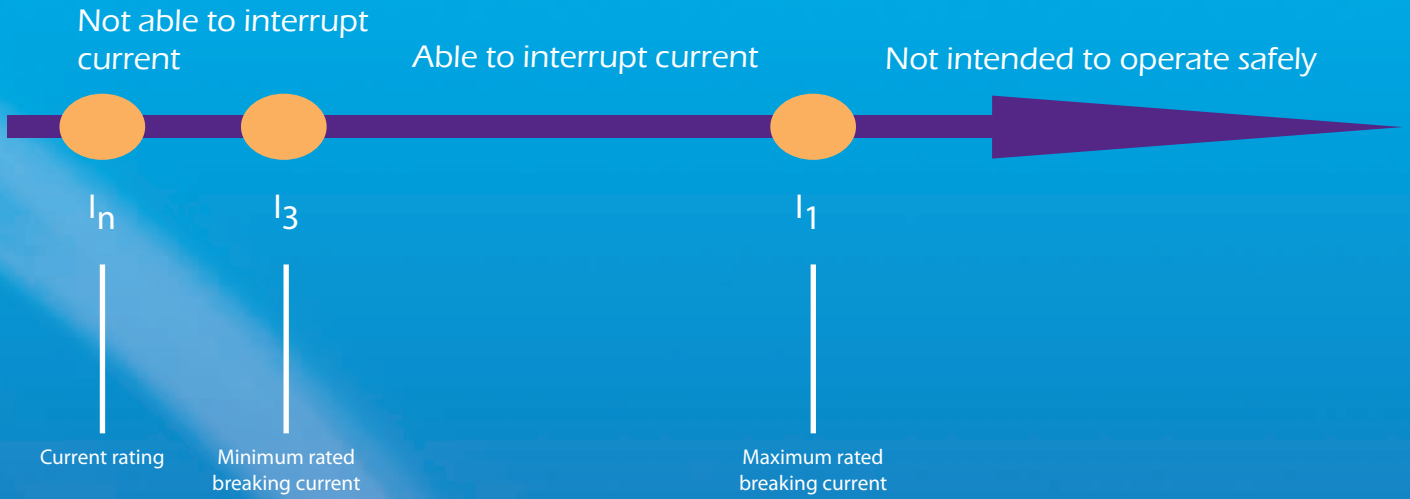

Back-up fuse-links range with CPD (Controlled Power Dissipation)

The CPD designed by Ferraz Shawmut controls the power dissipation of the fuse-link according to Ohm's law. The striker of all the Limitor® high voltage fuse-links published here are of medium-type (80N class) as per the VDE 0670 T4 standard (strikers are ranked as per the energy they release between two specified points during their trip). As the back-up fuse-link is combined with a transformer switch the CPD releases the switch before a too high power level is dissipated by the fuse-link.

General Purpose Fuse-links

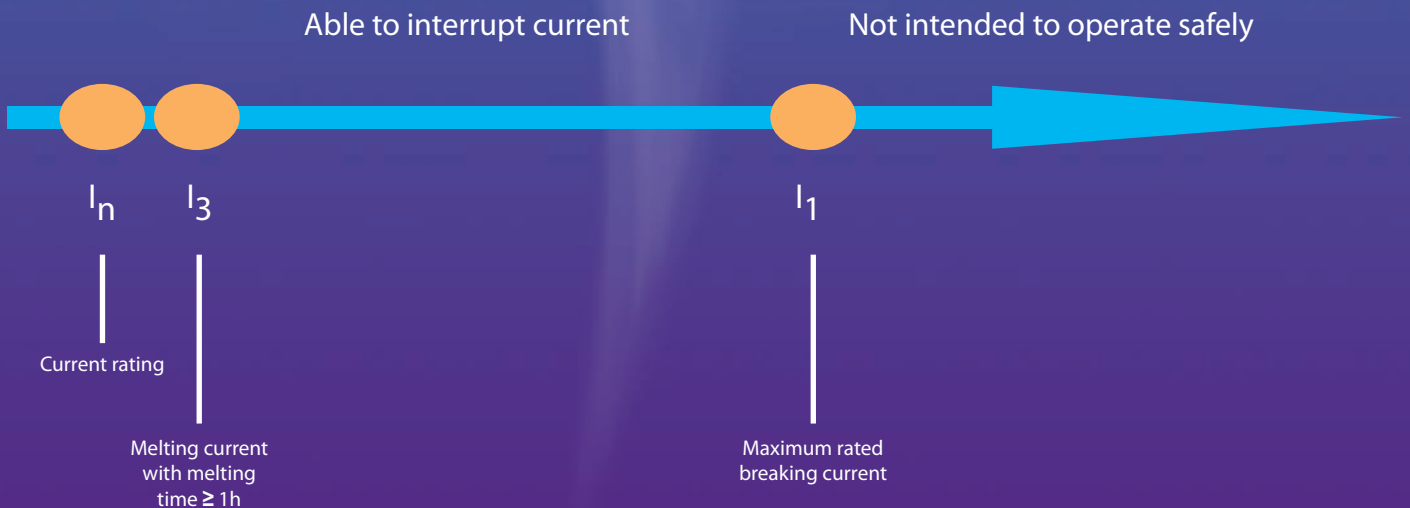

Contents

General Information	7
Explanation of Terms/Definitions	7 – 8
Protection of Transformers/Selection Criteria	9
Back-up Fuse-Links according to VDE 0670 T 402: Selection table	10
Back-up Fuse-Links according to VDE 0670 T 402: Technical data	11
Back-up Fuse-Links according to VDE 0670 T 402: Time-current characteristics	12
Back-up Fuse-Links according to VDE 0670 T 402 with CPD (Controlled Power Dissipation): general information	13
Back-up Fuse-Links according to VDE 0670 T 402 with CPD: Selection table	14
Back-up Fuse-Links according to VDE 0670 T 402 with CPD: Technical data	14
Back-up Fuse-Links in conjunction with switch-fuse combinations according to VDE 0671 T105	15
HV Fuse-Bases for indoor/outdoor use according to DIN 43 624, fuse-base contacts	16
General purpose fuse-links according to VDE 0670 T 4: General information	17
General purpose fuse-links according to VDE 0670 T4: Selection table and technical data	18
General purpose fuse-links according to VDE 0670 T 4: time current characteristics	19

General information

HV fuse-links have been used for reliable protection in medium-voltage switchgear and controlgear and systems for decades. They protect apparatus and equipment against the thermal and dynamic effects of short-circuits. The outstanding features of Limitor HV fuse-links from Ferraz Shawmut are:

- High breaking capacity
- High current limitation
- Low switching voltage
- Quick breaking
- Non-ageing

Limitor HV fuse-links conform to the following standards:

- VDE 0670 T 4 / IEC 60282-1: High-voltage fuse-links "current limiting fuse-links"
- VDE 0670 T 402: Selection of current-limiting fuse for transformer circuits
- IEC 60 787: Application guide for the selection of fuse-links of high-voltage fuse-links for transformer circuit applications
- VDE 0670 T303/IEC 60 420: High-voltage alternating current switch-fuse combinations
- DIN 43 625: High-voltage fuse-links, rated voltages 3,6 to 36kV (fuse-link dimensions)
- DIN 43 624: High-voltage fuse-links, rated voltages 3/3,6 to 30/36kV (single-pole fuse-link bases)

The quality management system of Ferraz Shawmut is certified to the international standard DIN ISO 9001 (EN 29001).

Ferraz Shawmut operates a certified environment management system. Ferraz Shawmut manufactures HV fuse-links with dimensions conforming to DIN 43 625 with striker for indoor and outdoor use, where the striker serves for actuating a trip-free mechanism as well as an indicator due to its red colour. In addition to the HV fuse-links shown in this brochure, Ferraz Shawmut also manufactures a wide range of special fuse-links in special dimensions. If you have a particular application that requires special fuse-link protection problems, simply ask the Ferraz Shawmut team, we are there for you.

Terms and definitions

Back-up fuse-links

Back-up fuse-links have a "rated minimum breaking current" from which the fuse-links are able to interrupt current. Backup fuse-links are not supposed to operate below their "minimum breaking current" (below I_3). Their operating range is from I_3 to the maximum rated breaking current (I_1). For the assignment of back-up fuse-links, it is important to note that the lowest short circuit current is higher at the site of the HV back-up fuse-link than I_3 ($I_{Kmin} > I_3$). If the short circuit current is lower than the minimum breaking current, additional protection must be provided.

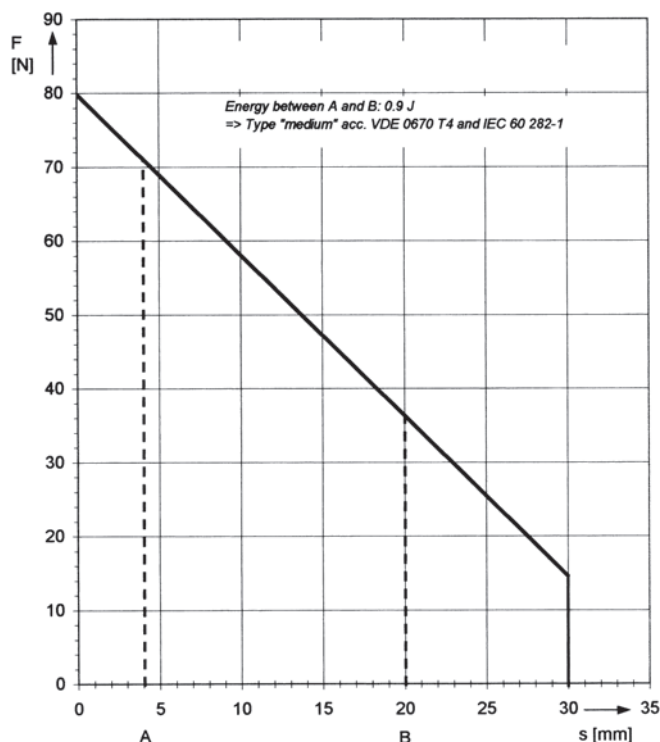

Striker

The striker of HV fuse-links in this product list has an effective length of 30 mm and is a «medium» type. This classification results from the energy released by the striker between the points A and B (within the first 20 mm of the operating distance. The initial force is about 80N, the force at the end of free movement is about 15N.

The striker serves for actuation of the trip-free mechanism of the switch

General purpose fuse-links

General purpose fuse-links have an extended operating range for low currents. These fuse-links are capable of interrupting all currents from a current that causes the fuse-link to melt within a time not less than 1 hour up to the "maximum rated breaking current" (I_1). These fuse-links are therefore also able to reliably interrupt low fault currents.

Rated voltage range

It is important for HV fuse-links that they must be operated at the voltage for which they have been rated. Accordingly, the operating voltage corresponds to the maximum rated voltage of the fuse-link. Owing to the switching voltage occurring during arcing, the fuse-link cannot be used at lower voltages without limitation. A lower operating voltage at which the fuse-link can still be used without exceeding the system insulation level during extinction must therefore be taken into account.

From these two values results the permissible voltage range of the fuse-link, which is shown on the fuse-links or in the technical data, e.g. 10/24kV.

Breaking capacity I_1

The breaking capacity is also referred to as the “rated maximum breaking current”. This clearly indicates that this is the maximum current which can be interrupted by the fuse-link. I_1 of the fuse-link must be greater than the maximum short circuit current at the site of the fuse-link ($I_1 > I_{Kmax}$).

Minimum breaking current I_3

The minimum breaking current is referred to as the “rated minimum breaking current”. This value must be specified for back-up fuse-links. From this current, back-up fuse-links are capable to breaking fault currents. The fuse-links must be assigned to the system so that no fault current below I_3 can occur at the site of the fuse-link (due to the system parameters or other protective devices).

Power dissipation of a fuse-link P_{warm}

The power dissipation of a HV fuse-link is specified at the rated current of the fuse-link. For protection with HV fuse-links, it should be noted that the operating current is normally half the rated current. Because of the physical relationships, the actual power dissipation is less than a quarter of the value P_{warm} for HV fuse-links shown in the technical data table.

Time-current characteristic (I/t characteristic)

The time-current characteristic shows the correlation between current and time up to the melting of a fuse-element. The virtual time (t_{vs}) is specified to enable a comparison of the I/t characteristics of fuse-links below 100ms. For co-ordination with other protective devices, e.g. load interrupter switches or circuit breakers, the melting integral I^2t must be referred to for melting times below 100ms.

Current limitation

At high short circuit currents, HV fuse-links interrupt current within several milliseconds that means, the sinusoidal current does not reach its peak value and that HV fuse-links are current limiting devices. This is a significant advantage compared to mechanical switches whose contacts take longer to open and interrupt currents at natural zero. During this time, the peak short-circuit current is able to freely develop its dynamic force. By using HV fuse-links, this surge current is limited within several ms to a fraction of its peak value and the design of the subsequent system can be reduced in terms of dynamic forces.

Switching voltage

So that HV fuse-links perform a current-limiting action, the short circuit current must be limited and reduced as it increases. This requires a switching voltage that exceeds the driving system voltage and forces the current to zero. This switching voltage must not exceed the specified permissible value of 2.2 times the peak value of the maximum rated voltage. Limiting HV fuse-links are within this limit.

Dimensions

HV fuse-links in this product list conform to DIN 43 625. The contact cap dimensions defined in this standard are shown in Fig. 2. The dimension "e" varies depending on the rated voltage of HV fuse-links, which is shown as a dimension for fuse-links in the technical data tables. The diameter "d" also varies with the rated current, whereby this dimension is also shown in the tables.

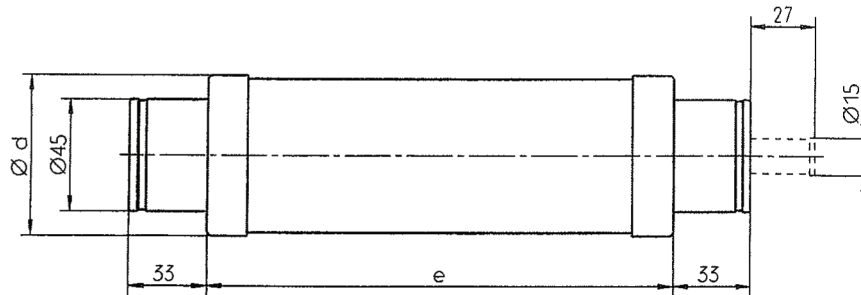

Fig. 2 : Dimensions acc. to DIN 43 625 in mm

Protection of transformers

The following should be observed for HV fuse-link selection:

- a) Transformer ratings
 - Service voltage (U)
 - Rated output (S)
 - Relative short-circuit voltage (U_k %)
 - Inrush current (factor 8...12 I_N)
- b) Time-current characteristic of HV fuse-links
- c) Secondary devices/selectivity

Procedure based on an example:

A 630kVA transformer has a transformer rated current of 18,2A at a service voltage of 20kV. The relative short-circuit voltage is 4% and the inrush current is $12 \times I_N$. The short-circuit current on secondary terminal short-circuit is given from the relative short-circuit voltage. The transformer must be designed to withstand this current for 2 seconds. This condition results in point b) in Fig. 3. HV fuse-links must interrupt this current within 2 seconds. In Fig. 3, the fuse link F4 must not be used for this transformer, as the fuse-link will require longer than 2 seconds to melt at this short-circuit current.

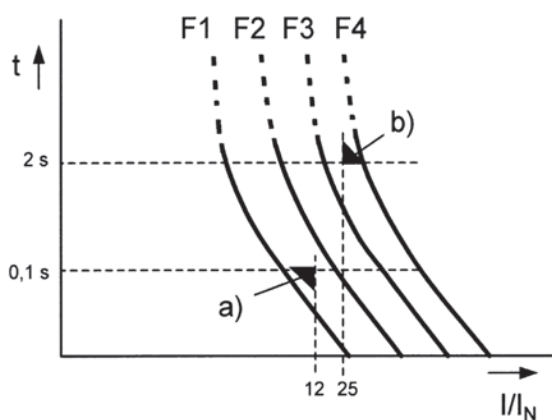

Fig. 3
F1 – F4) Time-current characteristics of HV fuse-links
a) Inrush current
b) lowest short-circuit current of transformer

The inrush current is plotted for a duration of 0,1 seconds, resulting in point a). This inrush current must not melt the fuse-link, for which reason the fuse-link F1 cannot be used for this transformer. The fuse-links F2 and F3 can be used for this transformer, since their time-current characteristics are between the points a) and b). A transformer can thus be assigned several HV fuse-links for various rated currents. Decisive for selection of the correct fuse is the time-current characteristic and not the rated current of the HV fuse-link.

The German standard VDE 0670 T402, defines time-current ranges for rated currents, whereby the points a) and b) as well as the selectivity to the LV fuse-links of the utilization category gTr have also been taken into account. If an HV fuse-link is assigned to a transformer according to T402, all of the above factors must be taken into account for correct HV fuse-link selection.

Selection table for HV back-up fuse-links acc. to VDE 0670 T 402

Rated voltage range of fuse-link [kV] Service voltage of transformer [kV]	Mode of protection Rated current of fuse-link [A]	Transformer output [kVA]											
		rel. short circuit voltage										U _K = 5%	
		50	100	125	160	200	250	315	400	500	630	800	1000
3/7,2	Transformer rated current [A]	4,8	9,6	12	15,4	19,2	24,1	30,3	38,5	48,1	60,6	77,1	96,3
	with NH gG	16	20-25	25-31,5	31,5-40	40-50	50-63	63-80	80-100	100-125	125-160	160	160
6	Transformer rated current [A]		20-25	25-31,5	31,5-40	40-50	50-63	63-80	80-100	100-125	125-160	160	160
	with NH gTr		20-25	25-31,5	31,5-40	40-50	50-63	63-80	80-100	100-125	125-160	160	160
6/12	Transformer rated current [A]	2,9	5,8	7,2	9,2	11,5	14,4	18,2	23,1	28,9	36,4	46,2	57,7
	with NH gG	10	16	16	20-25	25-31,5	31,5-40	40-50	50-63	63-80	80-100	100-125	100-125
20	Transformer rated current [A]		16	16	20-25	25-31,5	31,5-40	40-50	50-63	63-80	80-100	100-125	125-160
	with NH gTr		16	16	20-25	25-31,5	31,5-40	40-50	50-63	63-80	80-100	100-125	125-160
10/24	Transformer rated current [A]	1,5	2,9	3,6	4,6	5,8	7,2	9,1	11,5	14,4	18,2	23,1	28,9
	with NH gG	6,3	10	10	16	16	16-25	25	25-31,5	31,5-40	40-50	63	63
20	Transformer rated current [A]		10	10	16	16	16-25	25	25-31,5	31,5-40	40-50	63	63-80
	with NH gTr		10	10	16	16	16-25	25	25-31,5	31,5-40	40-50	63	63-80
20/36	Transformer rated current [A]	1	1,9	2,4	3,1	3,8	4,8	6,1	7,7	9,6	12,1	15,4	19,2
	with NH gG		6,3	10	10	16	16-20	20-25	25	25-31,5	31,5-40	40-50	40-50
30	Transformer rated current [A]		6,3	10	10	16	16-20	20-25	25	25-31,5	31,5-40	40-50	40-50
	with NH gTr		6,3	10	10	16	16-20	20-25	25	25-31,5	31,5-40	40-50	40-50
	Transformer rated current [A]	72	144	180	231	289	361	455	577	722	909	1155	1443
	with NH gG [A]	80	125/160	160/200	200/250	250/315	315/400	400/500	500/630	630/800	800/1000	1000/1250	1250/1600
0,4	with NH gTr [A]		100	125	160	200	250	315	400	500	630	800	1000

Table 1

Bold type figures are preferred values

HV Back-up Fuse-Links according to VDE 0670 T 402

Catalogue No.	Reference N°	Range	U_N (kV)	I_N (A)	L (mm)	D (mm)	I_1 (kA)	I_3 (A)	R (mΩ)	P (W)	I^2t (kA ² s)	Weight (kg)
45DB72V6,3PD	S209293A	Outdoor with striker	3/7,2	6,3	192	56	63	21	256	11	0,8	1,1
45DB72V10PD	T209294A	Outdoor with striker	3/7,2	10	192	56	63	38	144	19	3	1,1
45DB72V16PD	V209295A	Outdoor with striker	3/7,2	16	192	56	63	65	41	13	2,34	1,1
45DB72V20PD	W209296A	Outdoor with striker	3/7,2	20	192	56	63	92	32	14,5	3,9	1,1
45DB72V25PD	X209297A	Outdoor with striker	3/7,2	25	192	56	63	110	25	20	4,9	1,1
45DB72V32PD	Y209298A	Outdoor with striker	3/7,2	31,5	192	56	63	123	19	23	7	1,1
45DB72V40PD	Z209299A	Outdoor with striker	3/7,2	40	192	56	63	140	12,5	30	14	1,1
45DB72V50PD	A209300A	Outdoor with striker	3/7,2	50	192	56	63	194	9,25	35	25,3	1,1
45DB72V63PD	M1000235A	Outdoor with striker	3/7,2	63	192	65	63	220	7	60	61,7	1,4
45DB72V80PD	N1000236A	Outdoor with striker	3/7,2	80	192	65	63	300	5,2	85	87,4	1,4
45DB72V100PD	P1000237A	Outdoor with striker	3/7,2	100	192	78	63	440	4	96	180	2
45DB72V125PD	Q1000100A	Outdoor with striker	3/7,2	125	192	88	63	440	3	75	440	2,4
45DB72V160PD	O1000238A	Outdoor with striker	3/7,2	160	192	88	63	610	2,3	120	654	2,4
45DB120V6,3PD	R1000239A	Outdoor with striker	6/12	6,3	292	56	63	23	409	19	0,8	1,6
45DB120V10PD	S1000240A	Outdoor with striker	6/12	10	292	56	63	35	231	29	3	1,6
45DB120V16PD	T1000241A	Outdoor with striker	6/12	16	292	56	63	64	69	21	3,7	1,6
45DB120V20PD	V1000242A	Outdoor with striker	6/12	20	292	56	63	90	53	25	4,7	1,6
45DB120V25PD	W1000243A	Outdoor with striker	6/12	25	292	56	63	95	41	31	4,92	1,6
45DB120V32PD	X1000244A	Outdoor with striker	6/12	31,5	292	56	63	110	31	39	7	1,6
45DB120V40PD	Y1000245A	Outdoor with striker	6/12	40	292	56	63	134	20	46	14	1,6
45DB120V50PD	Z1000246A	Outdoor with striker	6/12	50	292	56	63	190	16,7	62	25,3	1,6
45DB120V63PD	A1000247A	Outdoor with striker	6/12	63	292	65	63	220	11,7	60	63	2,1
45DB120V80PD	B1000248A	Outdoor with striker	6/12	80	292	65	63	345	8,7	82	87	2,1
45DB120V100PD	C1000249A	Outdoor with striker	6/12	100	292	78	63	400	6,7	96	180	3,1
45DB120V125PD	D1000250A	Outdoor with striker	6/12	125	292	88	63	480	4,9	117	440	3,7
45DB120V160PD	E1000251A	Outdoor with striker	6/12	160	292	88	63	610	3,8	175	654	3,7
45DB240V6,3PD	F1000252A	Outdoor with striker	10/24	6,3	442	56	63	23	640	32	0,8	2,3
45DB240V10PD	G1000253A	Outdoor with striker	10/24	10	442	56	63	36	386	48	2	2,3
45DB240V16PD	H1000254A	Outdoor with striker	10/24	16	442	56	63	73	127	43	2,34	2,3
45DB240V20PD	J1000255A	Outdoor with striker	10/24	20	442	56	63	91	97	53	3,9	2,3
45DB240V25PD	K1000256A	Outdoor with striker	10/24	25	442	56	63	116	74	64	6,5	2,3
45DB240V32PD	L1000257A	Outdoor with striker	10/24	31,5	442	56	63	125	61	85	7	2,3
45DB240V40PD	M1000258A	Outdoor with striker	10/24	40	442	56	63	161	43	103	14,2	2,3
45DB240V50PD	N1000259A	Outdoor with striker	10/24	50	442	65	63	230	35	116	24,2	3,1
45DB240V63PD	P1000260A	Outdoor with striker	10/24	63	442	65	63	350	25	163	46,4	3,1
45DB240V80PD	Q1000261A	Outdoor with striker	10/24	80	442	65	63	460	19	196	104	3,1
45DB240V100PD	R1000262A	Outdoor with striker	10/24	100	442	88	63	420	14	279	140	4,1
45DB360V6,3PD	S209362A	Outdoor with striker	20/36	6,3	537	56	31,5	23	827	39	0,6	2,7
45DB360V10PD	T209363A	Outdoor with striker	20/36	10	537	56	31,5	34	463	65	2	2,7
45DB360V16PD	V209364A	Outdoor with striker	20/36	16	537	56	31,5	70	210	67	2,34	2,7
45DB360V20PD	W209365A	Outdoor with striker	20/36	20	537	56	31,5	100	147	84	3,9	2,7
45DB360V25PD	X209366A	Outdoor with striker	20/36	25	537	56	31,5	110	125	100	6,5	2,7
45DB360V32PD	Y209367A	Outdoor with striker	20/36	31,5	537	65	31,5	135	85	119	7	3,7
45DB360V40PD	Z209368A	Outdoor with striker	20/36	40	537	65	20	200	65	176	14,2	3,7
45DB360V50PD	J1000117A	Outdoor with striker	20/36	50	537	88	20	220	42	183	40	6,5
45DB360V63PD	K1000118A	Outdoor with striker	20/36	63	537	88	20	280	35	271	61,7	6,5

Table 2

HV back-up fuse-links acc. to VDE 0670 T 402 with and without controlled power dissipation

Time current characteristics

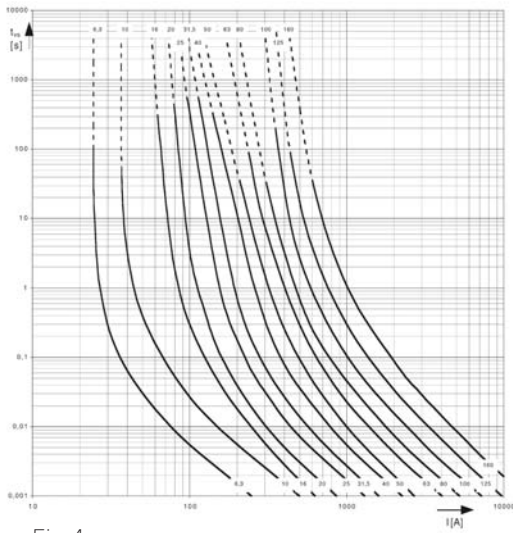

Fig.4
3/7,2 kV

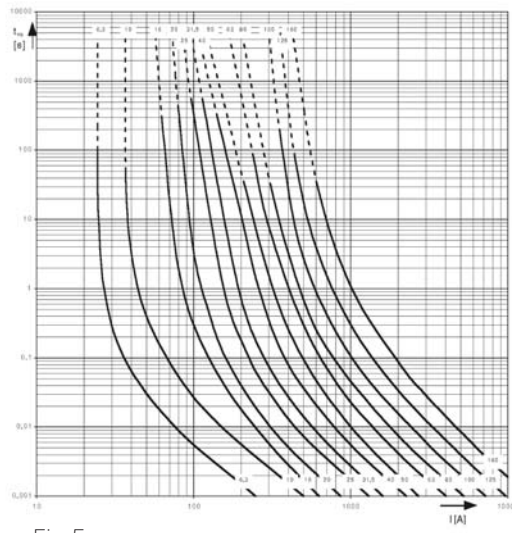

Fig.5
6/12 kV

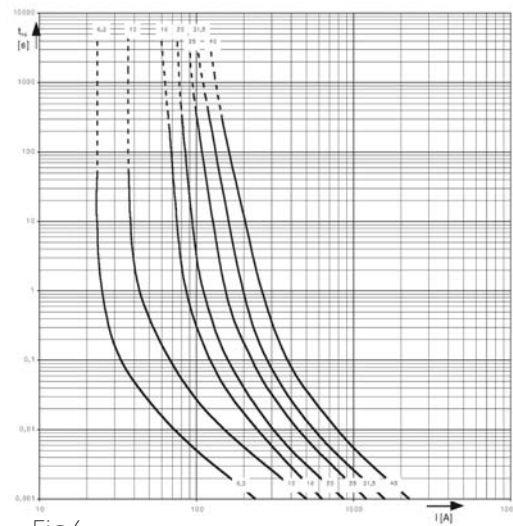

Fig.6
10/24 kV 6,3 A-40 A

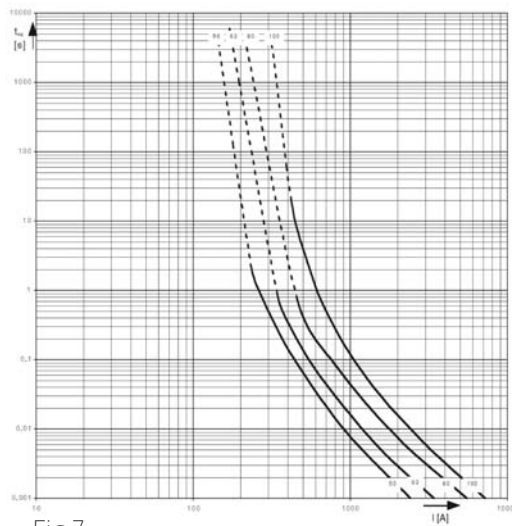

Fig.7
10/24 kV 50 A-100 A

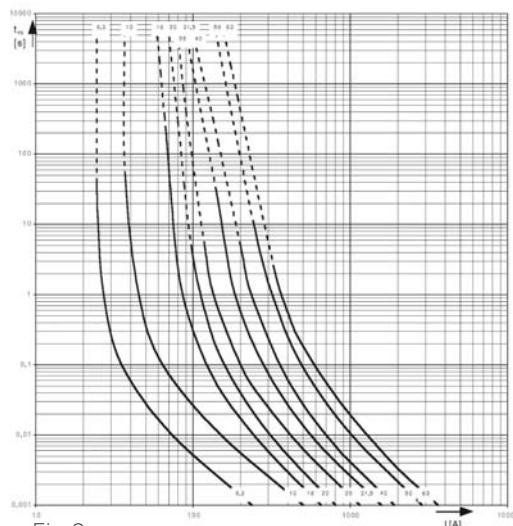

Fig.8
20/36 kV

HV back-up fuse-links according to VDE 0670 T 402 with controlled power dissipation CPD

Application

Limiter HV fuse-links type CPD meet the requirements of VDE 0670 T402 and were specifically developed to be installed in compact sized enclosed SF₆ insulated sub-stations. In these substations HV fuse-links are enclosed in narrow fuse compartments which on the one hand prevent efficient cooling of the fuse-links and on the other hand have a limited thermal power acceptance themselves (as a rule about 75 W).

Overheating of fuse compartments in such enclosures is, however, not to be expected, if the fuse-links have been properly selected by their rated current according to the transformer to be protected (see table 3) and if the melting elements of the fuse-links are in faultless condition (Fig. 9).

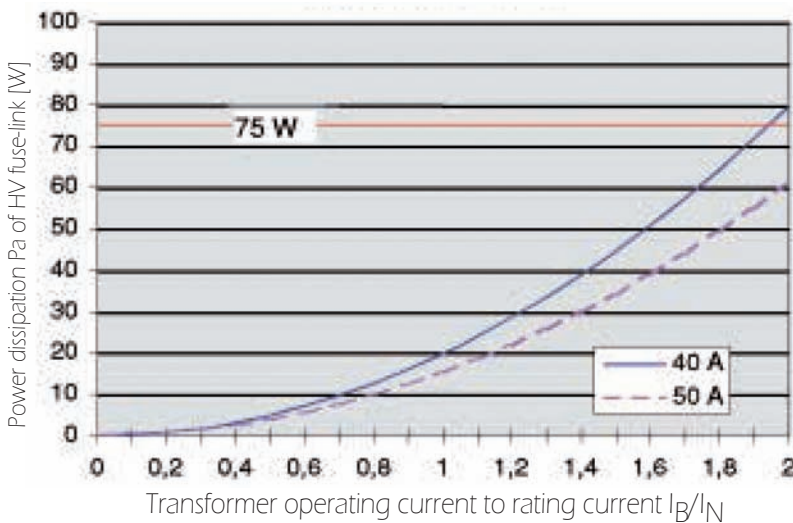

Fig. 9: Power dissipation of HV fuse-links 40 A and 50 A for a 20 kV, 630 kVA transformer

One or more of the melting elements connected in parallel may, however, be interrupted by transient currents caused by transformer inrush or lightning strikes. Fuse-links having one or more of the parallel melting elements interrupted, dissipate significantly more heat than faultless fuse-links.

There is a certain risk that the limited power acceptance of fuse compartments may be exceeded at or even below rated transformer current. HV back-up fuse-links type CPD prevent such potential overheating when installed in conjunction with a transformer switch having trip-free mechanism.

Function mode

As a rule, the power acceptance of fuse compartments in SF₆ insulated switchgear is limited, to e.g. 75 W. In order to prevent thermal overheating, the power dissipation P_a of the fuse must not exceed this value: $P_a \leq 75 \text{ W}$

The CPD striker system controls the power dissipation of the fuse according to Ohm's law (CPD means controlled power dissipation). The striker pin is released depending on the voltage drop across the fuse and, therefore depending on the power dissipation:

$$U_a = R \cdot I_B$$

$$U_a \cdot I_B = P_a \leq 75 \text{ W}$$

The release voltage U_a of the CPD striker system has been selected so that the fuse carrying the operating current I_B does not exceed the limiting value, e.g. 75 W, when the resistance R of the fuse increases because of interrupted melting elements. In this case the CPD striker system controls the power dissipation of the fuse and releases the transformer switch before the permissible power acceptance of the fuse compartment will be exceeded (Fig. 10).

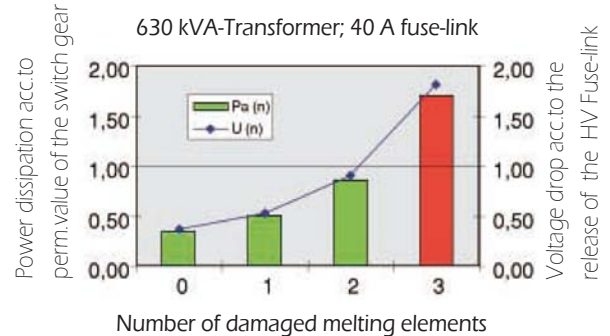

Fig. 10: Controlled power dissipation at 1.3 times transformer rated current

Benefits of thermal protection of the fuse compartment by CPD

- CPD controls the power dissipation of the fuse-links
- CPD is based on Ohm's law
- CPD works independent on the mounting position of the fuse
- CPD releases the striker, before an overheating is reached
- CPD mechanism is non-ageing

Selection table HV back-up fuse-links acc. to VDE 0670 T402 with controlled power dissipation CPD

Rated voltage range of fuse-link [kV] Service voltage of transformer [kV]	Mode of protection Rated current of fuse-link [A]	Transformer output [kVA]										
		rel. short-circuit voltage					U _K = 4%			U _K = 5%		
		100	125	160	200	250	315	400	500	630	800	1000
6/12	Transformer rated current [A]	5,8	7,2	9,2	11,4	14,4	18,2	23,1	28,9	36,4	46,2	57,7
	Rated current of fuse-link [A]	16	16	20	25	31,5	40	50	63	80	100	125
10	Power dissipation of HV fuse-links at rated current of transformer [W]	2,4	3,6	4,5	5,3	6,7	8,6	10,7	10,4	13,1	20,8	18,3
	Transformer rated current [A]	2,9	3,6	4,6	5,8	7,2	9,1	11,6	14,4	18,2	23,1	28,9
10/24	Rated current of fuse-link [A]	10	10	16	16	$\frac{16}{25}$	25	$\frac{25}{31}$	31,5	40	63	63
	Power dissipation of HV fuse-links at rated current of transformer [W]	3,3	5	2,9	4,6	$\frac{7,2}{3,8}$	6,2	$\frac{10,2}{8,3}$	13	15,2	14	22,7
20/36	Transformer rated current [A]	1,9	2,4	3,1	3,8	4,8	6,1	7,7	9,6	12,1	15,4	19,2
	Rated current of fuse-link [A]	6,3	10	10	16	16	20	25	25	31,5	40	$\frac{40}{50}$
30	Power dissipation of HV fuse-links at rated current of transformer [W]	2,8	3	4,7	3	4,5	5,6	6,5	10	12,3	16,9	$\frac{27,6}{17,3}$

Table 3

HV back-up fuse-links acc. to VDE 0670 T 402 with controlled power dissipation

Catalogue No.	Reference N°	Range	U _N (kV)	I _N (A)	L (mm)	D (mm)	I ₁ (kA)	I ₃ (A)	R (mΩ)	P (W)	I ² t (A ² s)	Weight (kg)
45DB120V10PTD	S1000263A	Back-up, striker, CPD	6/12	10	292	56	63	35	227	29	3.000	1,6
45DB120V16PTD	T1000264A	Back-up, striker, CPD	6/12	16	292	56	63	64	66	21	3.700	1,6
45DB120V20PTD	V1000265A	Back-up, striker, CPD	6/12	20	292	56	63	90	51	25	4.700	1,6
45DB120V25PTD	W1000266A	Back-up, striker, CPD	6/12	25	292	56	63	95	40	29	4.920	1,6
45DB120V32PTD	X1000267A	Back-up, striker, CPD	6/12	31,5	292	56	63	110	30	39	7.000	1,6
45DB120V40PTD	Y1000268A	Back-up, striker, CPD	6/12	40	292	56	63	134	20	46	14.000	1,6
45DB120V50PTD	Z1000269A	Back-up, striker, CPD	6/12	50	292	56	63	190	15	62	25.300	1,6
45DB120V63PTD	A1000270A	Back-up, striker, CPD	6/12	63	292	56	63	220	12	62	63.000	2,1
45DB120V80PTD	B1000271A	Back-up, striker, CPD	6/12	80	292	56	63	345	8,7	85	87.000	2,1
45DB120V100PTD	C1000272A	Back-up, striker, CPD	6/12	100	292	56	63	500	8,1	152	140.000	2,1
45DB120V125PTD	D1000273A	Back-up, striker, CPD	6/12	125	292	56	63	480	4,5	117	430.000	3,7
45DB120V160PTD	E1000274A	Back-up, striker, CPD	6/12	160	292	56	63	610	4	175	670.000	3,7
45DB240V6,3PTD	F1000275A	Back-up, striker, CPD	10/24	6,3	292	65	63	23	640	31	800	2,3
45DB240V10PTD	G1000276A	Back-up, striker, CPD	10/24	10	292	65	63	36	386	48	2.000	2,3
45DB240V16PTD	H1000277A	Back-up, striker, CPD	10/24	16	292	88	63	73	127	42	2.340	2,3
45DB240V20PTD	J1000278A	Back-up, striker, CPD	10/24	20	292	88	63	91	97	53	3.900	2,3
45DB240V25PTD	K1000279A	Back-up, striker, CPD	10/24	25	292	88	63	116	73	60	6.500	2,3
45DB240V32PTD	L1000280A	Back-up, striker, CPD	10/24	31,5	442	56	63	125	57	84	7.000	2,3
45DB240V40PTD	M1000281A	Back-up, striker, CPD	10/24	40	442	56	63	161	41	96	14.200	2,3
45DB240V50PTD	N1000282A	Back-up, striker, CPD	10/24	50	442	56	63	230	35	146	24.200	3,1
45DB240V63PTD	P1000283A	Back-up, striker, CPD	10/24	63	442	56	63	350	24	163	46.400	3,1
45DB240V80PTD	Q1000284A	Back-up, striker, CPD	10/24	80	442	56	63	460	19	196	104.000	3,1
45DB240V100PTD	R1000285A	Back-up, striker, CPD	10/24	100	442	56	63	420	14	279	140.000	4,1
45DB360V6,3PTD	S1000286A	Back-up, striker, CPD	20/36	6,3	442	56	63	23	889	39	600	2,7
45DB360V10PTD	T1000287A	Back-up, striker, CPD	20/36	10	442	56	63	34	529	66	2.000	2,7
45DB360V16PTD	V1000288A	Back-up, striker, CPD	20/36	16	442	56	63	70	190	67	2.340	2,7
45DB360V20PTD	W1000289A	Back-up, striker, CPD	20/36	20	442	56	63	100	153	84	3.900	2,7
45DB360V25PTD	X1000290A	Back-up, striker, CPD	20/36	25	442	56	63	110	118	100	6.500	2,7
45DB360V32PTD	Y1000291A	Back-up, striker, CPD	20/36	31,5	442	56	63	135	82	119	7.000	3,7
45DB360V40PTD	Z1000292A	Back-up, striker, CPD	20/36	40	442	65	63	205	63	176	14.200	3,7
45DB360V50PTD	A1000293A	Back-up, striker, CPD	20/36	50	442	78	63	220	41	183	40.000	6,5

Table 4

High-voltage alternating current switch-fuse combinations acc. to VDE 0671 T105

In order to increase the utilization range of a switch, it is combined with current limiting HV fuse-links. This combination unit offers short-circuit protection in addition to load switching capacity. HV fuse-links provide short-circuit protection, while the switch interrupts the currents below the take-over current of the combination unit.

In addition to the inrush current, short-circuit current on secondary terminal short-circuits and low voltage selectivity, the following switch characteristics should be taken into account:

- Rated transfer current ($I_{transfer}$)
- Fuse-initiated opening time of the switch (t_0)

Fig. 11 shows the rated transfer current ($I_{transfer}$) as a vertical line. The fuse-initiated opening time (t_0) must be multiplied by 0,9 (procedure according to VDE 0671 T105 and a horizontal line be drawn. This results in an intersection that is characteristic to the switch and must be established for each switch individually.

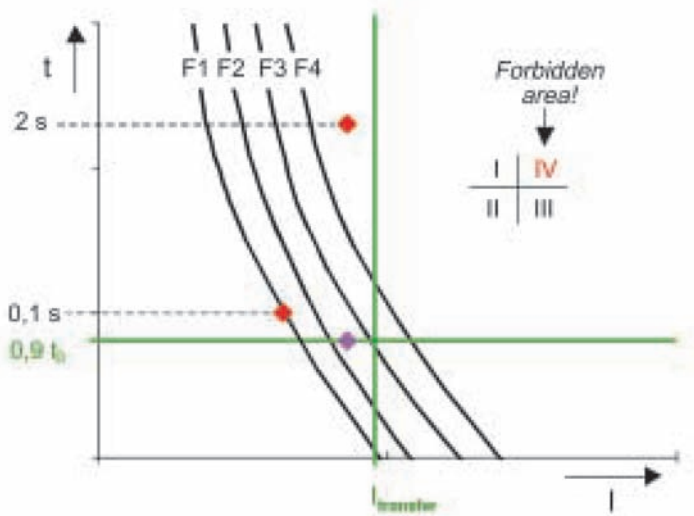

Fig. 11 : Selection of HV fuse-links acc. to VDE 0671 T105

This switch intersection divides the sheet into four quadrants (see Fig. 11).

Suitable for the switch-fuse combination are HV fuse-links only with a time-current characteristic that does not pass through quadrant IV ("forbidden area").

Generally suitable for use in switch-fuse combinations according to VDE 0671 T105 are all HV fuse-links with striker which meet this criterion.

Ferraz Shawmut has assigned HV fuse-links to the switch-fuse combination and the transformers of all major manufactures. These documents are available on request.

Clips

Size	Reference.Number	Catalog Number	Packaging
MR 45 + spring	L096472A	MR45R	1
MR 45 without connection lug	S210236B	MR55R	2

Bases

Voltage (kV)	Size	Use	Reference.Number	Catalog Number	Packaging
7,2	SI 7,2/192	Indoor	G209421A	SI72V192	1
12	SI 12/292	Indoor	H209422A	SI120V292	1
17,5	SI 17,5/292	Indoor	J209423A	SI175V292	1
24	SI 24/442	Indoor	K209424A	SI 240V442	1
36	SI 36/537	Indoor	M209426A	SI360V537	1
12	SE 12/292	Outdoor	S210328A	SE120V292	1
17,5	SE 17,5/292	Outdoor	T210329A	SE175V292	1
24	SE 24/442	Outdoor	V210330A	SE240V442	1
36	SE 36/537	Outdoor	W210331A	SE360V537	1

Bases with signalling

Voltage (kV)	Number of contacts	Reference.Number	Catalog Number	Packaging
12/36	1 NO/NF	E092855A	MC1-5NFLEXQS500	1
12/36	2 NO/NF	F092856A	MC1-9NFLEXQS500	1

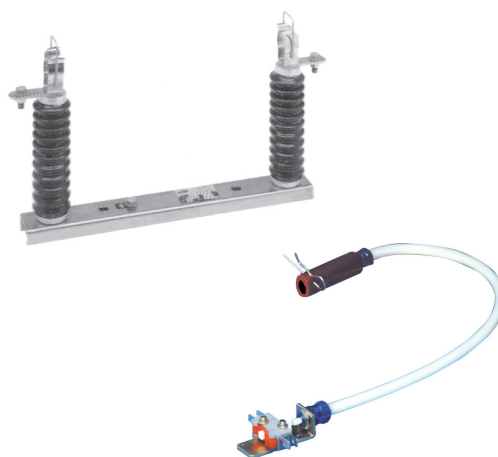
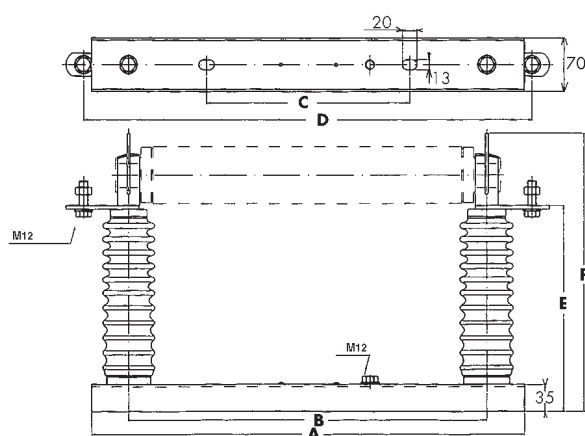

Cat. number	Ref. number	Use	Voltage Kv	Lenght of use L (mm)	Dielectric withstand (phase to ground)		Dimensions (mm)						Weight (Kg)
					50Hz-1mn Kv Rms	1,2/50µs peak voltage	A	B	C	D	E	F	
SI72V192	G209421A	Indoor	7,2	192	20	60	400	226	322	347	175	270	3,8
SI120V292	H209422A	Indoor	12	292	28	75	424	324	200	445	175	270	4,1
SI175V292	J209423A	Indoor	17,5	292	38	95	424	324	200	445	220	315	5,1
SI175V367	Q1001089A	Indoor	17,5	367	38	95	576	401	270	522	218	313	6
SI240V442	K209424A	Indoor	24	442	50	125	576	476	270	597	270	365	5,5
SI360V537	M209426A	Indoor	36	537	70	170	670	570	350	691	354	449	7,7
SE120V292	S210328A	Outdoor	12	292	28	75	424	324	200	445	261	356	7,5
SE175V292	T210329A	Outdoor	17,5	292	38	95	424	324	200	445	261	356	7,5
SE175V367	V1001070A	Outdoor	17,5	367	38	95	576	401	270	521	263	358	10,1
SE240V442	V210330A	Outdoor	24	442	50	125	576	476	270	597	309	404	8,8
SE360V537	W210331A	Outdoor	36	537	70	170	670	570	350	691	381	476	13,2

HV general purpose fuse-links acc. to VDE 0670 T4

HV general purpose fuse-links have an extended breaking range for low currents. By connecting two melting elements in series in one body, a special time-current characteristic results.

This enables selectivity between HV fuse-links and low voltage circuit-breakers. Whilst one system can reliably interrupt low melting currents with long melting times (up to one hour), the other system interrupts high short-circuit currents. The time-current characteristic thus consists of two sections, where the takeover point (intersection) lies at about one second (see I/t characteristic F1 in Fig. 12).

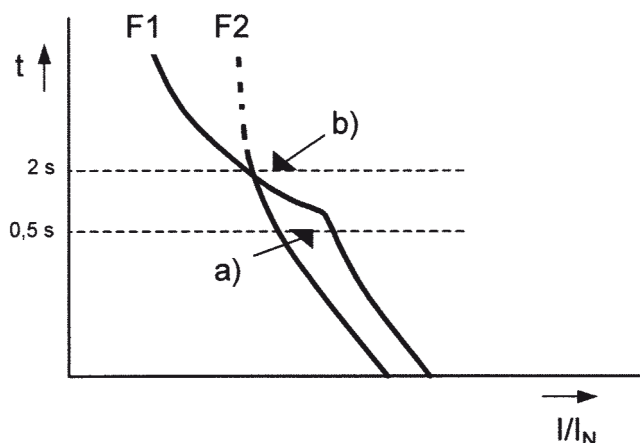

Fig. 12

F1) Time-current characteristic of general purpose fuse-link

F2) Time-current characteristic of back-up fuse-link

a) Selectivity to low voltage circuit breaker

b) lowest short-circuit current of transformer

In Fig. 12, point b) corresponds to the short-circuit current of a transformer. Point a) is the release current of a circuit breaker on the low voltage side, e.g. which is set to a release time of 0,5 seconds, transformed on the high-voltage side.

The transformer is protected by both fuse-links with the I/t characteristics F1 and F2, as the short-circuit current is interrupted within two seconds. If a selectivity of the HV fuse-link to the circuit-breaker (point a) is required, an HV general purpose fuse-link must be used on the high-voltage side. The time-current characteristic F1 is located to the right of point a) of the circuit-breaker in contrast to the I/t characteristic F2 of the HV back-up fuse-link, which would already melt prior to tripping of the circuit-breaker. In a special manufacturing process, these HV general purpose fuse-links can also be produced in an oil-tight version and directly integrated into the transformer. These fuse-links without striker are provided with a threaded connection on both ends and can be operated under the oil of a transformer

Advantages of using HV general purpose fuse-links are:

- All currents, from the current that causes the melting element to melt within a time of ≥ 1 hour up to the maximum rated breaking current I_1 being reliably interrupted
- Insensitive to lightning impulse current, low inrush sensitivity
- Very low power dissipation/low heating
- Selectivity to low voltage circuit-breaker possible
- HV general purpose fuse-links can be integrated into the transformer as an oil-tight variant

Selection table for HV general purpose fuses VDE 0670 T4

Rated voltage range of fuse-link [kV] Service voltage of transformer [kV]	Mode of protection Rated current of fuse-link [A]	Transformer output [kVA]											
		rel. short-circuit voltage										U _K = 5%	
		50	100	125	160	200	250	315	400	500	630	800	1000
6/12	Transformer rated current [A]	4,8	9,6	12	15,4	19,2	24,1	30,3	38,5	48,1	60,6	77,1	96,3
6	Rated current of fuse-link [A]	6,3	16	16	16-25	25	25-40	40	40-50	50	50	-	-
6/12	Transformer rated current [A]	2,9	5,8	7,2	9,2	11,5	14,4	18,2	23,1	28,9	36,4	46,2	57,7
10	Rated current of fuse-link [A]	6,3	6,3-10	10	16	16	16-25	25	25-40	40	40-50	50	50
10/24	Transformer rated current [A]	1,5	2,9	3,6	4,6	5,8	7,2	9,1	11,5	14,4	18,2	23,1	28,9
20	Rated current of fuse-link [A]	-	4	4-6,3	6,3	6,3-10	10	16	16	16	25	25	25

Table 5

Electrical data, dimensions, weights

Catalogue No.	Reference N°	Range	U _N [kV]	I _N (A)	L (mm)	D (mm)	I ₁ (kA)	R (mΩ)	P (W)	I ² t (kA ² s)	Weight (kg)
45DG120V6,3P	W1000151A	Outdoor, striker, general purpose	6/12	6,3	292	65	40	128	6	2	2,3
45DG120V10P	X1000152A	Outdoor, striker, general purpose	6/12	10	292	65	40	70	8	3,8	2,3
45DG120V16P	Y1000153A	Outdoor, striker, general purpose	6/12	16	292	65	40	35	10	14	2,3
45DG120V25P	Z1000154A	Outdoor, striker, general purpose	6/12	25	292	65	40	20,5	15	36	2,3
45DG120V40P	A1000155A	Outdoor, striker, general purpose	6/12	40	292	78	40	12,2	24	110	3,1
45DG120V50P	B1000156A	Outdoor, striker, general purpose	6/12	50	292	88	40	9,9	31	150	3,7
45DG240V4P	C1000157A	Outdoor, striker, general purpose	10/24	4	442	78	40	280	5	1,8	4,1
45DG240V6,3P	D1000158A	Outdoor, striker, general purpose	10/24	6,3	442	78	40	256,5	11	2	4,1
45DG240V10P	E1000159A	Outdoor, striker, general purpose	10/24	10	442	78	40	135	15	3,6	4,1
45DG240V16P	F1000160A	Outdoor, striker, general purpose	10/24	16	442	78	40	70,3	21	14	4,1
45DG240V25P	G1000161A	Outdoor, striker, general purpose	10/24	25	442	88	40	41,2	31	39	4,5

Table 6

HV general purpose fuse-links acc. to VDE 0670 T4: Time current characteristics

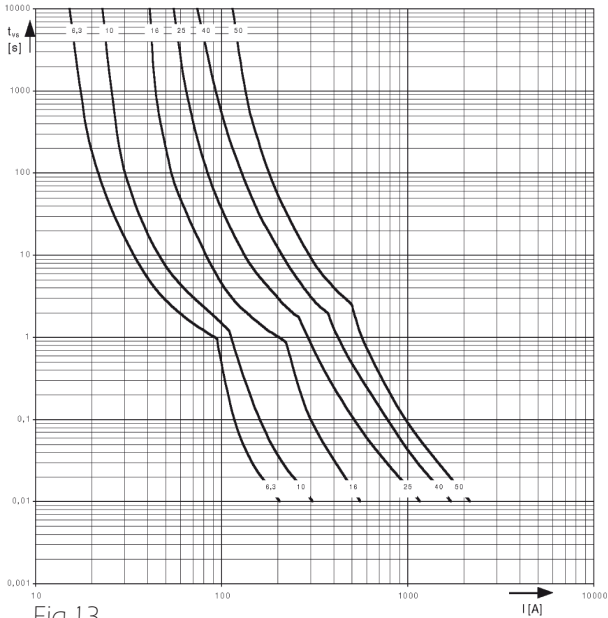

Fig.13
6/12 kV

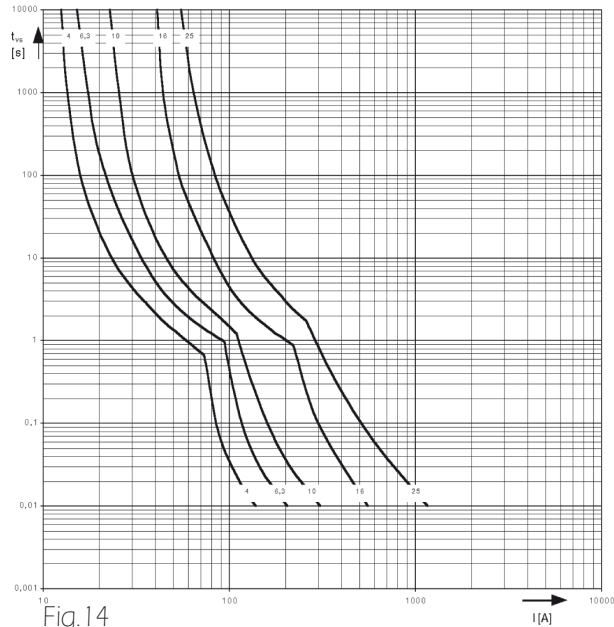

Fig.14
10/24 kV



Ferraz Shawmut SAS - 1, rue Jean Novel
69626 VILLEURBANNE Cedex - FRANCE
Tél. 33 (0)4 72 22 66 11 - Fax 33 (0)4 72 22 67 13

Ferraz Shawmut Inc. - 374 Merrimac Street
Newburyport, MA 01950 - USA
Tél. (978) 462-6662 - Fax (978) 462-0181

www.ferrazshawmut.com